

ARFM.3Y MOTORLAR / SPINDLES

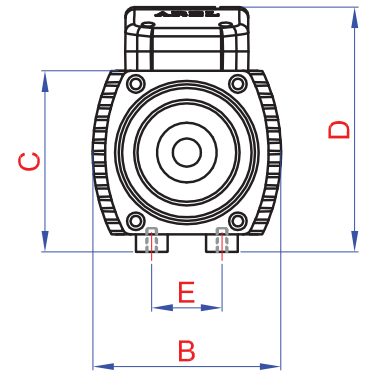
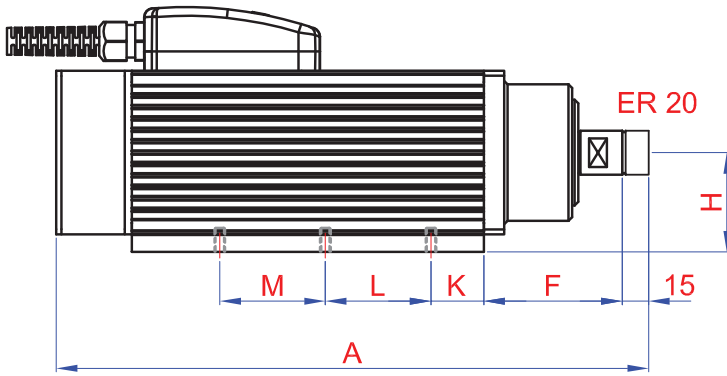
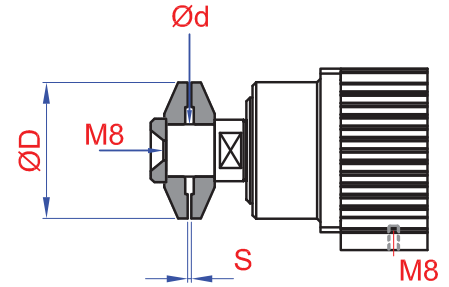

TİP / TYPE	A mm	B mm	C mm	D mm	E mm	F mm	H mm	K mm	L mm	M mm	Ø D mm	Ø d mm	S mm
ARFM.3Y-S	287	107	103	138	40	80	56,5	30	60	-	78	30	2
ARFM.3Y-M	337	107	103	138	40	80	56,5	30	60	60	78	30	2
ARFM.3Y-L	377	107	103	138	40	80	56,5	30	60	60	78	30	2

TİP / TYPE	KW / HP	Rpm	Hz.	Volt	Amper	Kg.	PENS / COLLETS
ARFM.3Y-S2	1,5 / 2	12.000	200	Δ 220-380 Y	5,3 / 3,1	6,85	ER 20 1 - 13 mm
ARFM.3Y-S3	2,2 / 3	18.000	300	Δ 220-380 Y	8 / 4,6	6,85	
ARFM.3Y-S4	0,37 / 0,5	3.000	50	Δ 220-380 Y	1,4 / 0,8	6,85	
ARFM.3Y-M2	2,2 / 3	12.000	200	Δ 220-380 Y	8 / 4,6	9	
ARFM.3Y-M3	3 / 4	18.000	300	Δ 220-380 Y	10,5 / 6	9	ER 25 1 - 16 mm
ARFM.3Y-M4	0,55 / 0,75	3.000	50	Δ 220-380 Y	1,1 / 1,9	9	
ARFM.3Y-L1	1,5 / 2	6.000	200	Δ 220-380 Y	5,3 / 3,1	10,85	
ARFM.3Y-L2	3 / 4	12.000	200	Δ 220-380 Y	10,4 / 6	10,85	
ARFM.3Y-L3	4 / 5,5	18.000	300	Δ 220-380 Y	14,2 / 8,2	10,85	
ARFM.3Y-L4	0,75 / 1	3.000	50	Δ 220-380 Y	2,6 / 1,6	10,85	