

**ARFM.1Y MOTORLAR / SPINDLES**

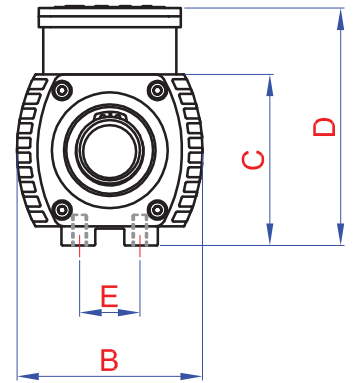
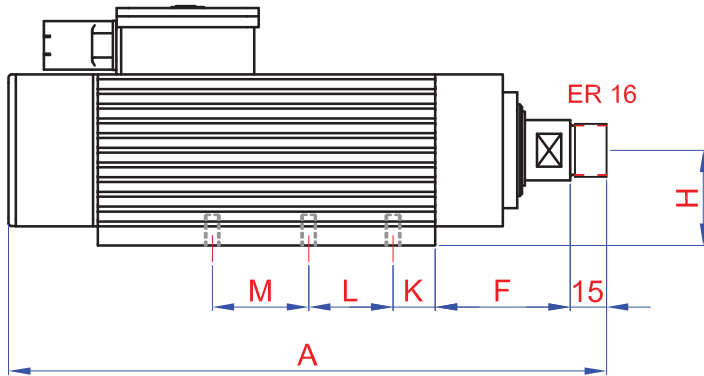
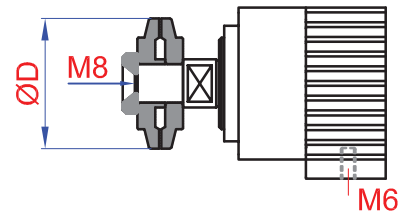
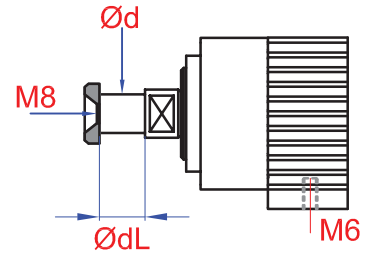
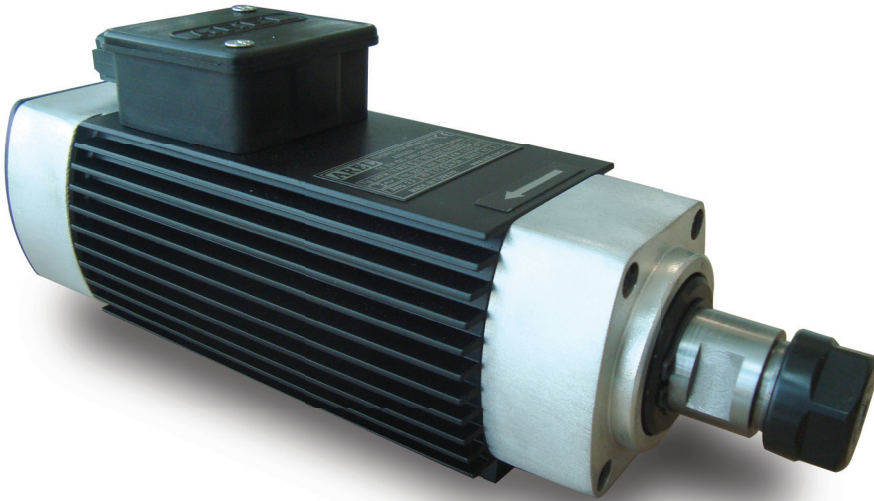

TİP / TYPE	A mm	B mm	C mm	D mm	E mm	F mm	H mm	K mm	L mm	M mm	Ø d mm	Ø D mm	Ø dL mm
ARFM.1Y-S	198	77	71	98	25	56	39,5	17,5	55	-	16	54	19
ARFM.1Y-M	248	77	71	98	25	56	39,5	17,5	35	40	16	54	19

TİP / TYPE	KW / HP	Rpm	Hz.	Volt	Amper	Kg.	PENS / COLLETS
ARFM.1Y-S2	0,18 / 0,25	12.000	200	220V - 3~	0,8	2,10	ER 11 1 - 7 mm
ARFM.1Y-S3	0,25 / 0,34	18.000	300	220V - 3~	1,1	2,10	
ARFM.1Y-M2	0,37 / 0,5	12.000	200	220V - 3~	1,6	3,10	
ARFM.1Y-M3	0,55 / 0,75	18.000	300	220V - 3~	2,2	3,10	ER 16 1 - 10 mm
ARFM.1Y-M4	0,75 / 1	24.000	400	220V - 3~	2,6	3,10	